

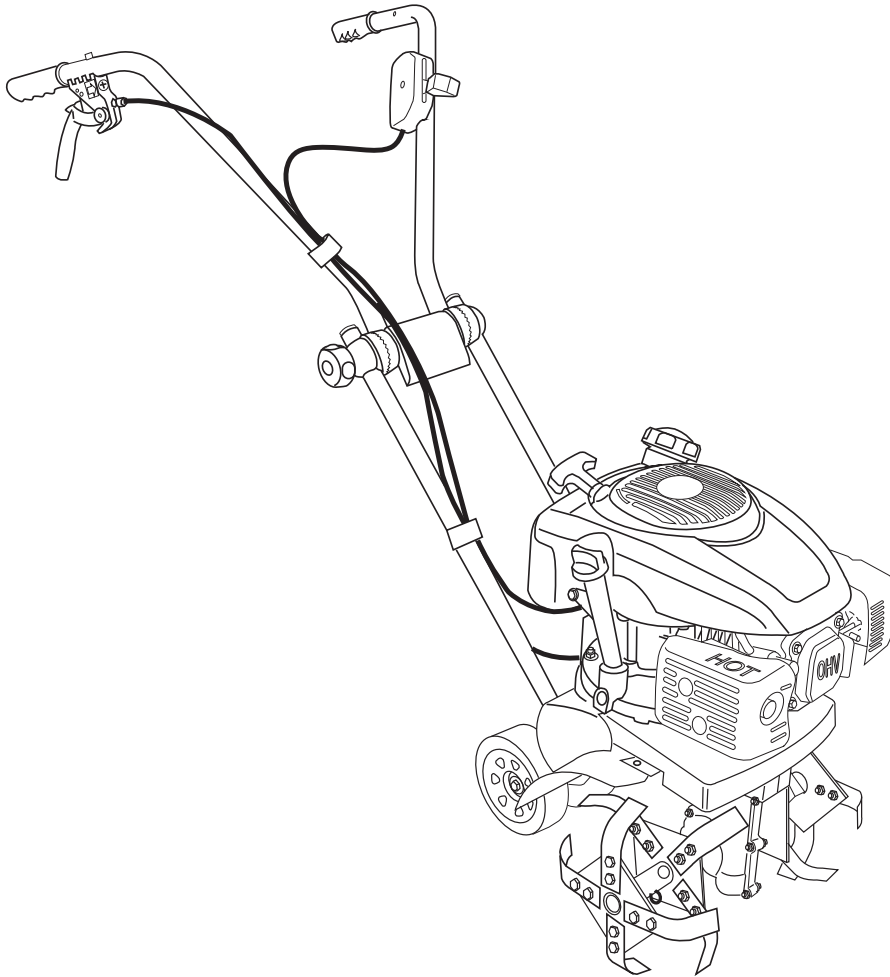

**DIRTY HAND  
TOOLS**

## 15" Front Tine Tiller



**MODEL # 101571**

# Operation Manual



**This safety alert symbol identifies important safety messages in this manual. Failure to follow this important safety information may result in serious injury or death.**

Part # 101790 Rev B

*Designed & Engineered in Colorado, USA*



*Assembled with Foreign & Domestic Components*

For Service or Questions

**Call 1-877-487-8275**

**720-287-5182**

**[www.dirtyhandtools.com](http://www.dirtyhandtools.com)**

Dirty Hand Tools® is a brand of



**FrictionlessWorld**

1100 W 120th Ave, Suite 600  
Westminster, CO 80234 • 720-287-5182

# Table of Contents

<b>Important Safety Information</b>	
Intended Use .....	4
Personal Protective Equipment .....	4
General Safety .....	5
Safety Decals .....	6
<b>Unpacking and Assembly Instructions</b>	
Unpacking .....	7
<b>Overview of Components</b> .....	8
Tine Assembly.....	9
Wheel/Depth Adjuster Assembly .....	9
Handlebar Assembly .....	10
Driver Safety Control Lever Mounting .....	11
Throttle Control Lever Mounting .....	11
Safety Shield Assembly .....	12
<b>Operating Precautions</b> .....	13
<b>Operating Instructions</b>	
Preparation for Operation .....	14
Pre-Start Inspection .....	14
Adjusting the Depth Regulator .....	14
Starting Up.....	15
Shutting Down.....	15
Tilling.....	16
Tilling Tips.....	16
<b>Maintenance</b>	
Lubrication.....	17
Cleaning the Tine Axle Shaft.....	17
Transmission Oil .....	17
Engine Maintenance .....	17
<b>Storage</b> .....	18
<b>Troubleshooting</b> .....	19
<b>Warranty &amp; Specifications</b> .....	Back Cover

# Important Safety Information



WARNING

**WARNING:** Read and thoroughly understand all instructions and safety information before assembling or operating this tiller. Failure to do so may cause serious injury or death. Do not allow anyone to operate this tiller who has not read this manual. As with all power equipment, a tiller can be dangerous if assembled or used improperly. Do not operate this tiller if you have doubts or questions concerning safe operation.

Call our customer service department at **720-287-5182**, **1-877-487-8275**, or visit [www.dirtyhandtools.com](http://www.dirtyhandtools.com) if you have any questions or concerns about the safe operation of this equipment.



DANGER

## Intended Use

Do Not Use the tiller for any purpose other than tilling garden soil for which it was designed. Any other use is unauthorized and may result in serious injury or death.

## Personal Protective Equipment

When operating this tiller it is essential that you wear safety gear including goggles or safety glasses, steel toed shoes and tight fitting gloves (no loose cuffs or draw strings). Always wear ear plugs or sound deafening headphones to protect against hearing loss when operating this tiller. Always wear sturdy footwear. Never wear sandals, sneakers or open shoes, and never operate the tiller with bare feet. Do not wear loose clothing that might get caught in moving parts.



CAUTION

**YOUR TILLER IS EQUIPPED WITH A SAFETY CONTROL LEVER THAT ENABLES YOU TO STOP THE TINES QUICKLY IN AN EMERGENCY.**

Learn how the drive safety control lever operates and how to control the tiller at all times.

**Read the entire Operation Manual before using this equipment!**

# Important Safety Information

## General Safety

Failure to follow warnings, cautions, assembly and operation instructions in the Operation Manual may result in serious injury or death.



DANGER

### READ THE OPERATION MANUAL BEFORE OPERATION.

- **Do not** permit children to operate this equipment at any time.
- **Do not** permit others that have not read and understood the complete Operation Manual to operate this equipment.
- Keep all people and pets a minimum of 10 feet away from the work area when operating this tiller.
- **Do not** operate the tiller when under the influence of alcohol, drugs or medication.
- **Do not** allow a person who is tired or otherwise impaired or not completely alert to operate the tiller.



DANGER

### CAREFULLY INSPECT THE AREA TO BE TILLED AND REMOVE ALL FOREIGN OBJECTS.

Do not till above underground water lines, gas lines, electric cables, or pipes. Do not operate the tiller in soil with large rocks and foreign objects which can damage the equipment.

- Leave control lever in the neutral position before starting the engine.
- Handle fuel with care; it is highly flammable. Use an approved fuel container. **Never add fuel to a running engine or hot engine.**
- Fill fuel tank outdoors with extreme care. **Never fill fuel tank indoors.**
- Replace gasoline cap securely and clean up spilled fuel before restarting.
- Never attempt to make any adjustments while the engine is running.

# Important Safety Information

## Safety Decals

Safety labels on the tiller are to remind you of important information while you are operating the unit. Make sure all safety warning decals are attached and in readable condition. Replace missing or defaced decals. Contact Dirty Hand Tools at **1-877-487-8275** for replacement decals.

**DANGER**

**AVOID INJURY FROM ROTATING TINES!**

**Keep hands, feet and clothing away!**

- Tines rotate when the safety latch is flipped up and the drive control lever is depressed towards the handle bar.
- **To stop tines from rotating release the drive control lever.** The safety latch automatically snaps into locked position.
- Stop the engine, wait for tines to stop rotating and **disconnect the spark plug** before removing debris or doing any maintenance.

101573

**WARNING**

**AVOID INJURY**

- **Read the Operator's Manual Before Operating**
- **Wear Safety Goggles or Eyewear**
- **Wear Boots or Protective Footwear**
- **Wear Protective Noise Reduction Gear**
- **Wear Gloves and Protective Clothing**

- Know the function and location of all controls.
- Never allow children to operate the tiller.
- Check area to be tilled and remove rocks or obstacles.
- Check for underground utilities before using.

101846

# Unpacking and Assembly

Your tiller will require some assembly. The following instructions will help you unpack your tiller, assemble and adjust the depth regulator lever, cable tension and handlebar height. You will need two 9/16" wrenches.

## Unpacking

Open top of carton and remove the tiller components.

### Tiller Components

- Upper Handlebar left
- Upper Handlebar right
- Lower Handlebars left and right
- Handlebar Face Plate
- Handlebar
- Wheels/Depth Regulator
- Safety Shields
- Tine Blades (2)
- Engine Assembly
- Driver Safety Control Lever (with cable)
- Throttle Assembly (with cable)
- Hardware



CAUTION

### **DO NOT ADD ENGINE OIL TO THE TRANSMISSION GEAR CASE**

The tiller transmission is filled at the factory.



CAUTION

### **DO NOT ATTEMPT TO START ENGINE BEFORE ADDING OIL TO ENGINE**

The engine is shipped from the factory without oil. You must add engine oil before starting the engine. Use only the recommended weight of oil for a 4-cycle engine (See Engine Operation Manual).

# Overview of Components

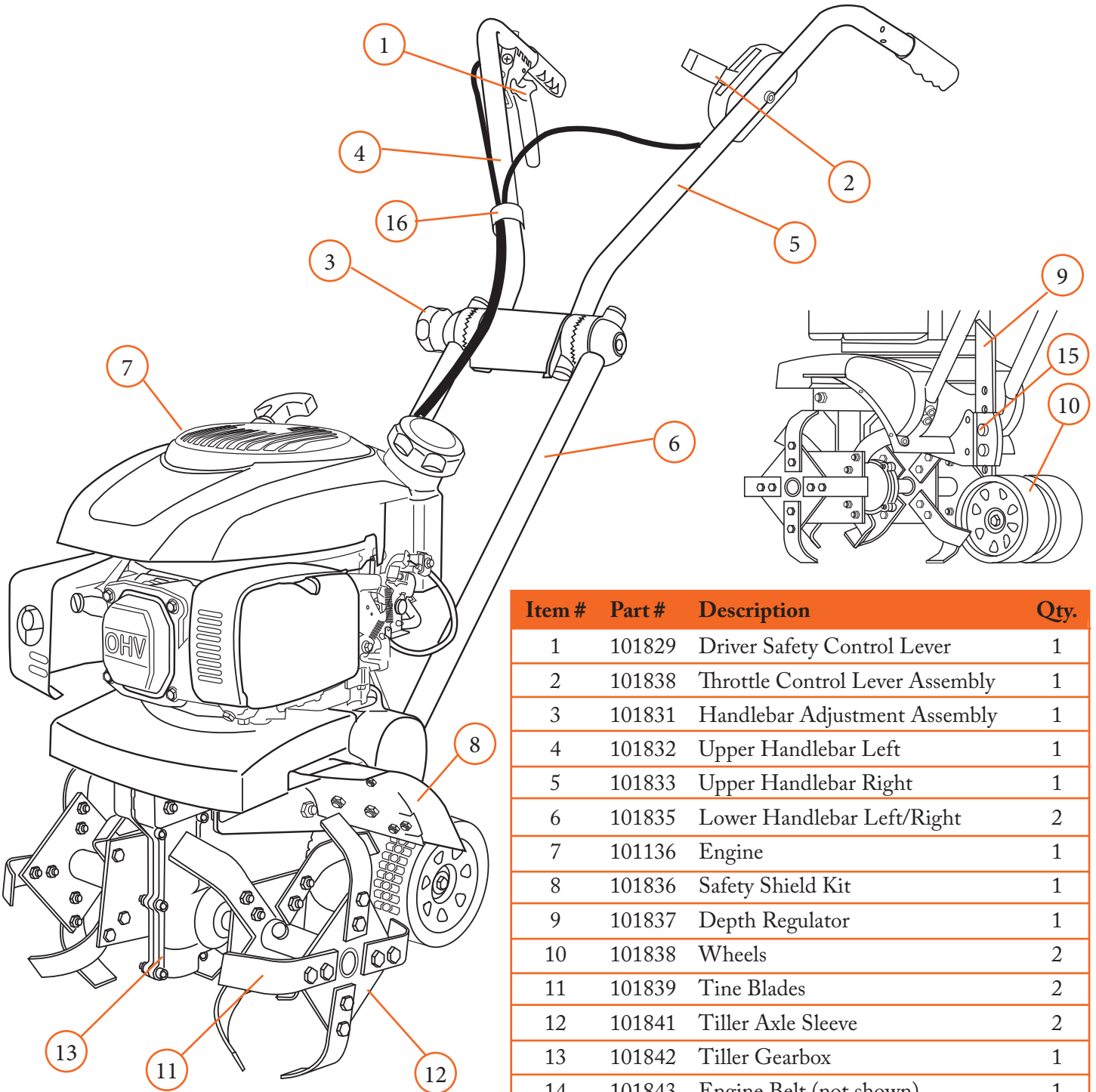

Item #	Part #	Description	Qty.
1	101829	Driver Safety Control Lever	1
2	101838	Throttle Control Lever Assembly	1
3	101831	Handlebar Adjustment Assembly	1
4	101832	Upper Handlebar Left	1
5	101833	Upper Handlebar Right	1
6	101835	Lower Handlebar Left/Right	2
7	101136	Engine	1
8	101836	Safety Shield Kit	1
9	101837	Depth Regulator	1
10	101838	Wheels	2
11	101839	Tine Blades	2
12	101841	Tiller Axle Sleeve	2
13	101842	Tiller Gearbox	1
14	101843	Engine Belt (not shown)	1
15	101845	Locking Pin	2
16	102893	Plastic Cable Clip	2
17	102894	Flat Lead Clevis with R-Clip	2



# Tine Assembly

## Mounting the Tine Blades

1. Slide the tines onto the tiller's axle. Align the connection holes and secure the tines to the tiller axle with a clevis pin and a R-clip (see Figure 1).

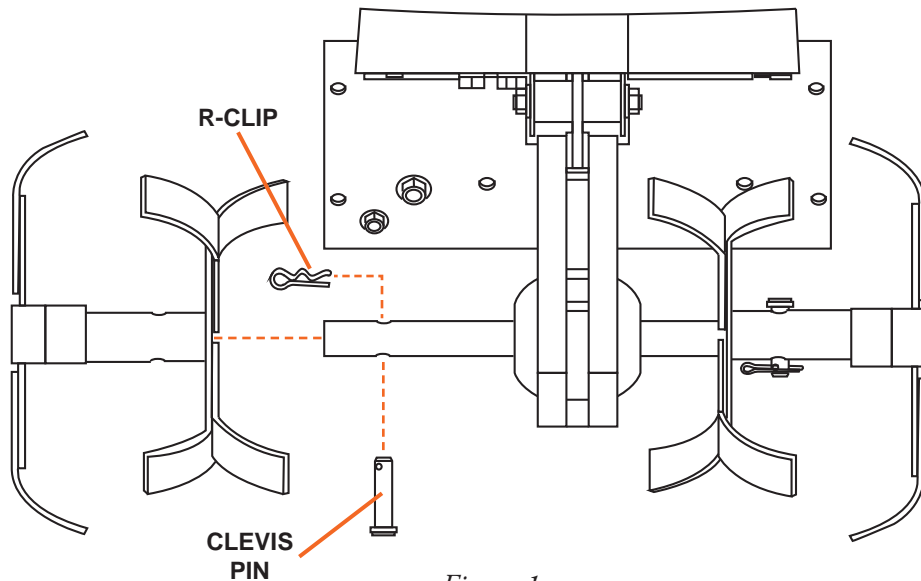

Figure 1

# Wheel/Depth Adjuster Assembly

## Mounting the Wheels/Depth Adjuster

1. Align two holes on the tiller wheel bracket at the desired height on the wheels/height adjuster.
2. Push two locking pins through the holes and secure (see Figure 2).

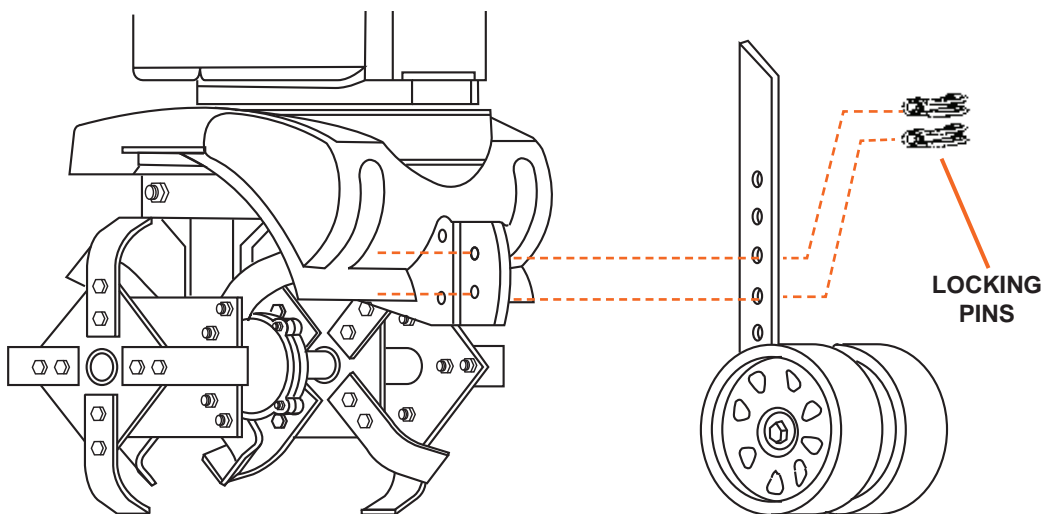

Figure 2

# Handlebar Assembly

## Mounting Lower Handlebars

NOTE: The left and right hand handlebars are identical. Each has two holes drilled in one side and one hole drilled in the opposite side of the handlebar tube. The two hole side of the handlebars should face inward toward each other (see Figure 3).

1. Attach the two lower handlebar tubes to the tiller with a tube support bracket and two hex bolts on each side (see Figure 4).
2. Position the handlebar components as shown in Figure 5.
3. Push the long threaded bolt through all of the components, then secure at the end with a hex nut.
3. Make height adjustments to the handlebars for operation comfort and tighten the handlebar adjustment knob securely.

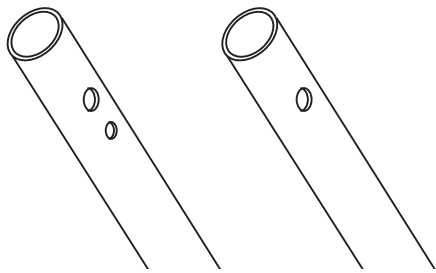

Figure 3

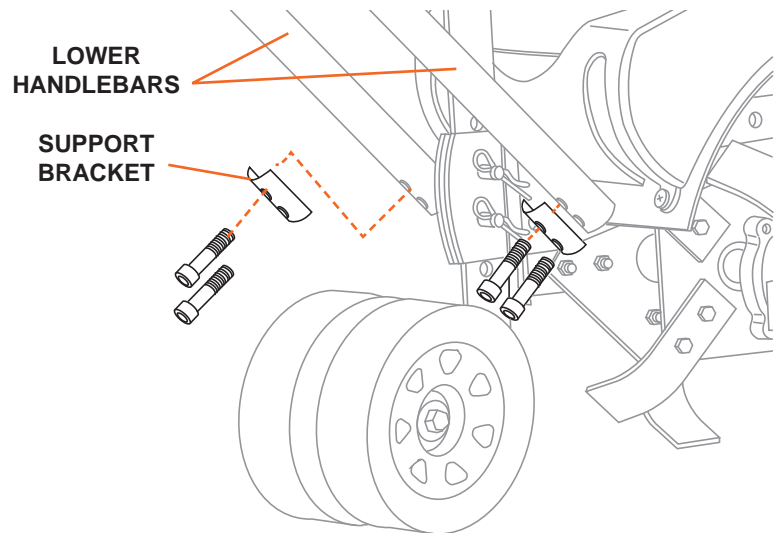

Figure 4

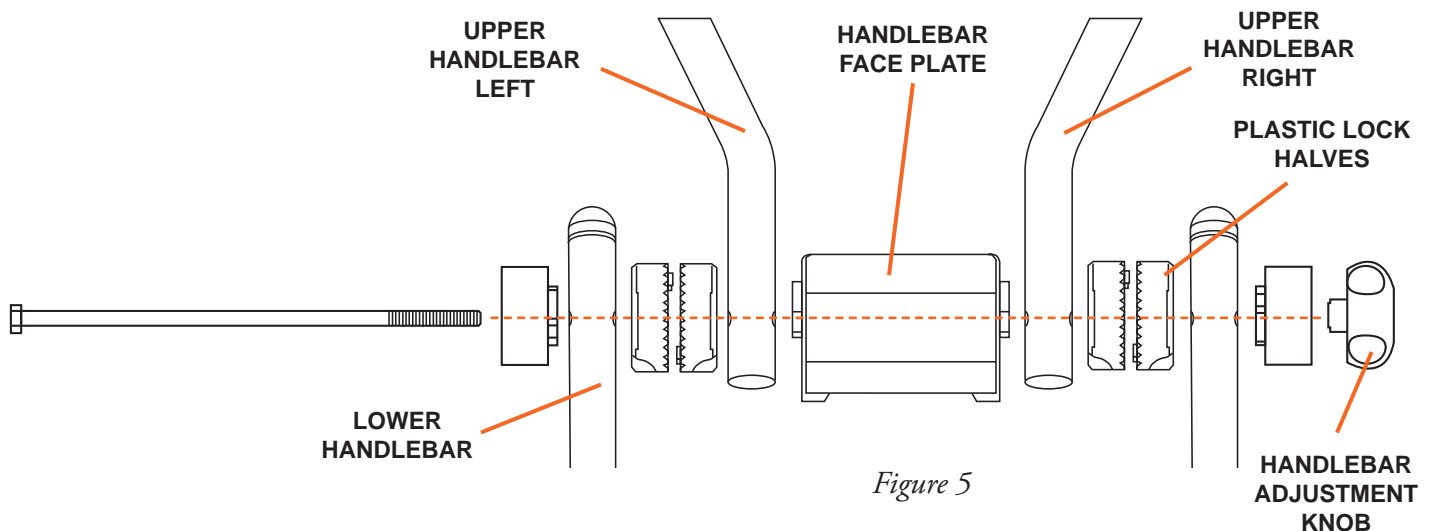

Figure 5

## Driver Safety Control Lever Assembly

### Mounting the Driver Safety Control Lever

1. Position the Driver Safety Control Lever onto the right handlebar.
2. Push a threaded hex bolt through the top of the handlebar into the safety control lever and tighten securely (see Figure 6).
3. Adjust the tension on the driver safety control lever by loosening the hex nut and rotating the threaded cable length adjuster. Then re-tighten the hex nut against the lever to lock the cable length.

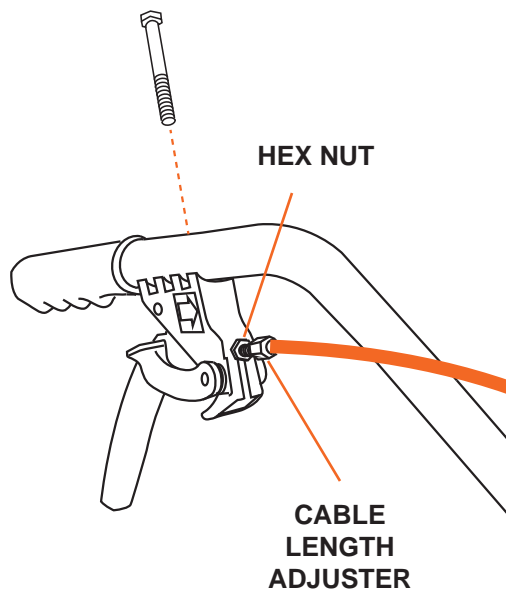

Figure 6

The correct tension will engage the tines about half way between being completely released and held all the way up against the handlebar grip.

**NOTE:** The driver safety control lever must be adjusted prior to use and checked periodically for the correct tension. Adjust the tension on the cable so the belt is firm when the lever is pulled up towards the handlebar grip. Use caution as to not over tension the cable as too much tension will cause excessive wear on the belt.

## Throttle Control Lever Assembly

### Mounting the Throttle Control Lever

1. Position the Throttle Control Lever onto the left handlebar.
2. Push a threaded hex bolt through the base of the lever and secure with a nylock hex nut (see Figure 7).

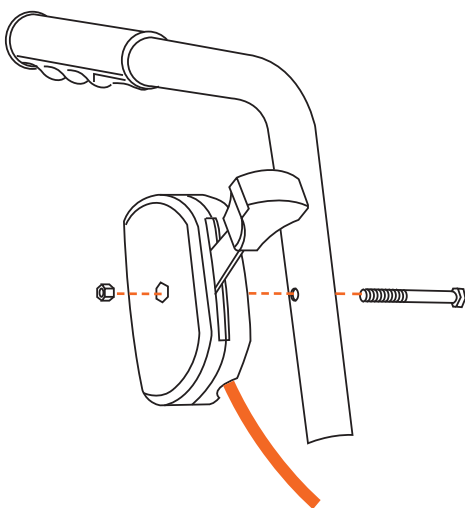

Figure 7

# Safety Shield Assembly

## Mounting Safety Shields to the Tiller

1. There are left and right hand Safety Shields. Each has three holes drilled through a mounting tab. Align the mounting tab with the holes drilled in the tiller and secure with a hex bolt through the top and a hex nut underneath the safety shield in three places on each side (see Figure 8).

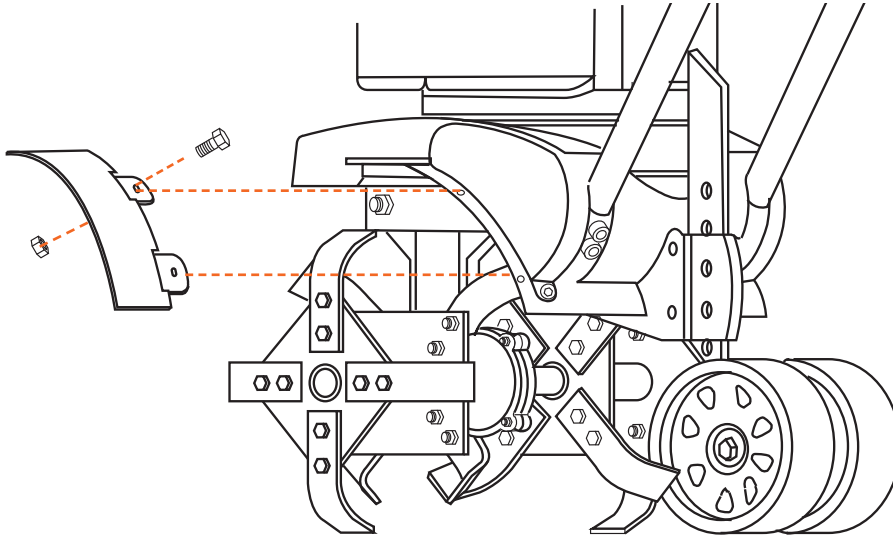

Figure 8

# Operating Precautions



CAUTION

**READ, UNDERSTAND AND FOLLOW ALL OF THE PRECAUTIONS BELOW.**

**Always perform the pre-start checklist before starting the engine.**

- **Never** operate the tiller without safety shields in place.
- **Keep hands, feet, and clothing away from rotating parts. Keep clear of tiller tines at all times.**
- Tines rotate when the engine is running and drive lever is depressed (pulled towards the handlebars). *Releasing the drive lever stops the tines.*
- **Use extreme caution** when operating on or crossing gravel drives, walks, or roads. Stay alert for hidden hazards or traffic.
- After striking an obstacle, **stop the engine**, remove the wire from the spark plug, inspect the tiller for damage and repair before restarting.
- If tines become clogged, **stop the engine** and **disconnect the spark plug wire** before removing any obstruction.
- **Engine muffler will be hot** from operation. Do not touch it with bare skin or a severe burn may result.
- If the unit vibrates abnormally, stop the engine and check immediately for the cause. *Vibration is an indication of a potential problem.*
- **Do not** run the engine indoors; exhaust fumes are deadly.
- **Do not** overload the tiller by trying to till too deep or too fast.
- **Never** operate the machine at high transport speeds on slippery surfaces. Look behind and use care when backing.
- Use only attachments and accessories approved by the manufacturer.
- **Never** operate the tiller without good visibility or adequate light.
- Be careful when tilling in hard ground. The tines may catch in the ground and propel the tiller backwards. *If this occurs, let go of the handlebars and do not restrain the machine.*
- **Take precautions when leaving the machine unattended.** Disengage all control levers, stop the engine, wait for all moving parts to stop, and make certain guards and shields are in place.
- **Shut off the engine when leaving the operating position** for any reason. Wait for all moving parts to stop.



WARNING

**OPERATION OF ANY TILLER CAN RESULT IN FOREIGN OBJECTS BEING THROWN. ALWAYS WEAR SAFETY GLASSES DURING OPERATION.**

# Operating Instructions

## Preparation for Operation



**THIS UNIT WAS SHIPPED WITHOUT OIL IN THE ENGINE. Check the oil level before each operation.**

### Fill Engine with Oil

1. Add oil according to engine manual. Do not overfill. Use SAE30 engine oil. **Do not mix oil with gasoline.** Oil level must be full. Check the oil level by removing oil fill plug (see Figure 9). Oil level should be up to the bottom of the fill plug opening.

### Pre-Start Inspection

1. Make sure safety shields are in place and nuts & bolts are secure.
2. Check oil level.
3. Inspect air cleaner (see Figure 10). Clean or replace as needed.
4. Check fuel supply. Fill the fuel tank no closer than 1 inch from top of tank to provide space for expansion.
5. Be sure spark plug wire is attached and is tightened securely.
6. Examine underneath and around engine for oil or fuel leaks.
7. Inspect fuel hoses for tightness and fuel seepage.
8. Look for signs of engine damage.
9. Remove excessive debris from muffler area and recoil starter.

### Adjusting the Depth Regulator

Remove the depth regulator, turn in opposite direction and reinstall with two locking pins (see Figure 11). Adjust the depth regulator up or down as required.

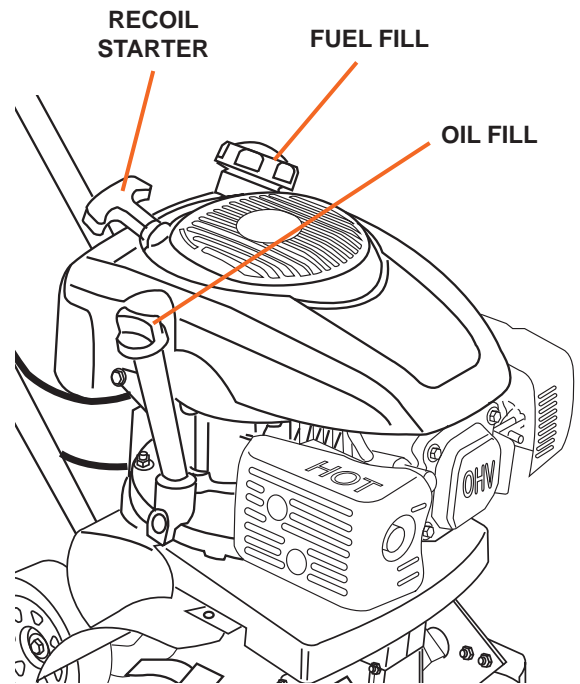

Figure 9

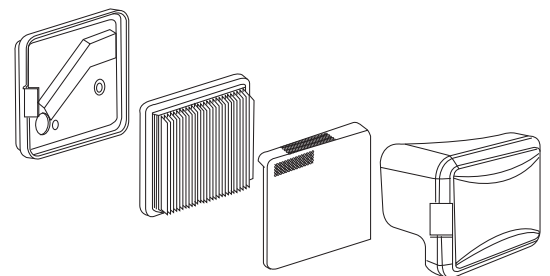

Figure 10

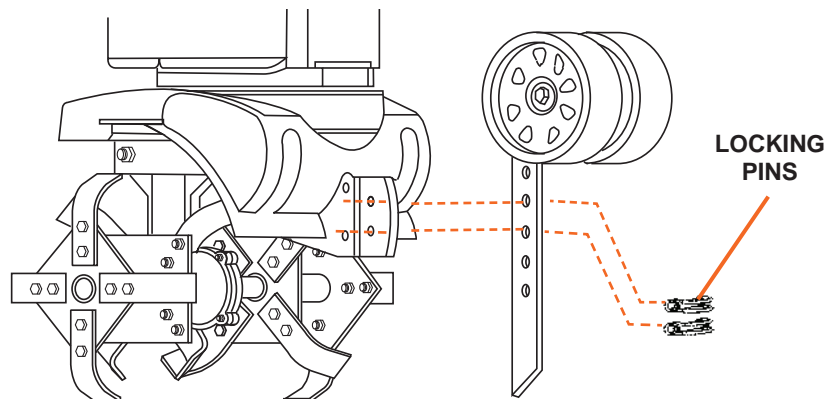

Figure 11

# Operating Instructions



## NEVER FILL THE FUEL TANK ON A HOT ENGINE

### Start-Up

The controls required to start and run the tiller are located on the engine and are marked “Choke” and “Throttle”. A detailed description of engine operation and precautions is available in the engine operation manual.



### Cold Starts

1. Move choke lever to full choke position.
2. Move throttle lever to “start”.
3. Pull starting rope out slowly one time and allow to return normally.
4. Pull starting rope out rapidly, and allow rope to return normally.
5. When engine starts, gradually move choke lever to “no choke” position and increase throttle speed.

### Restarting A Warm Engine

Restarting an engine that is already warm from previous running does not normally require use of the choke.

1. Move throttle lever to “start” position.
2. Pull starting rope out rapidly until engine starts. Allow rope to return normally. Repeat until engine starts.
3. Adjust throttle speed to “high” for best tiller action.

### Idle Speed

Use the “low” position on the throttle lever to reduce stress on the engine when tilling is not being performed. Lowering the engine speed to “idle” will help extend the life of the motor, as well as conserve fuel and reduce the noise level of the equipment.

### Operating Speed

For normal tilling, set the throttle lever to “fast”.

### Shutting Down

To stop the engine at any time, move throttle control to the STOP position. To stop tines at any time, release the drive control lever.

# Operating Instructions



WARNING

## PRACTICE OPERATING THE CONTROLS AND USING THE TILLER WITH TINES OUT OF GROUND BEFORE BEGINNING TO TILL.

It is important that you know how to use the tiller properly, keep control at all times, stop the tines and wheels from turning, and stop the engine if necessary.

**Read the entire Operation Manual before using the equipment!**

### Tilling

1. Start the engine.
2. Move the throttle control to fast.
3. Place the tiller in forward by pulling up on the drive lever - this will engage the tines.

**Note:** You can slow the tiller's forward advance at any time by putting slight downward pressure on the handlebars. Stop the tiller by releasing the drive lever and then stopping the engine.

### Drive Lever

Pulling the drive lever toward the handlebar engages the tines.

**Releasing the lever stops the tines** (see Figure 12).

### Tilling Tips

The key to successful tilling is to begin with a shallow cut on the first pass, and then work an inch or two deeper on each successive pass.

- Tilling depth will vary with ground conditions.
- When beginning to till in unbroken ground or in extremely hard soil perform shallow tilling first then do a second pass going deeper into the soil.
- Hold on firmly to the handlebars to control sudden lurches.

Immediately release the drive control lever if the tines jam or you strike a foreign object. With the drive lever in released, push the throttle control to stop position to stop the engine. Disengage the spark plug wire. When tines have stopped, remove foreign objects and check for damage.

Pulling the safety drive lever towards the handlebar engages the tines.

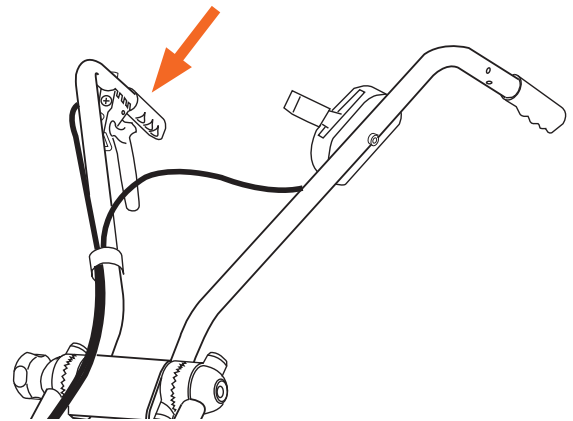

Figure 12



# Maintenance

- Keep tiller, safety shields and covers, attachments, and accessories in safe working condition.
- Check clevis pins, engine mounting bolts, and other bolts at frequent intervals for proper tightness to be sure the equipment is in safe working condition.
- To prevent accidental starting, always disconnect and secure the spark plug wire from the spark plug before maintenance.
- Never run the engine indoors. Exhaust fumes are toxic.
- Always allow muffler to cool before filling fuel tank.

## Lubrication

Proper lubrication of moving mechanical parts is critical for proper care and maintenance. Oil the cables and other moving parts at 10 hour intervals using a SAE30 engine oil.

## Checking Transmission Oil

The transmission oil is filled at the factory. Should it require filling use SAE30 engine oil and fill to top of the reservoir (see Figure 13).

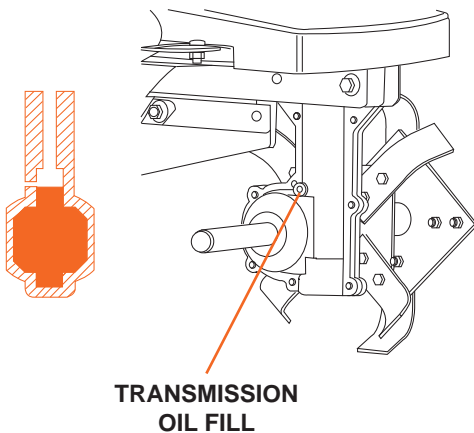

Figure 13

## Cleaning the Tine Axle Shaft

1. Turn off engine. Engine must be cool.
2. Remove spark plug wire and secure from spark plug.
3. Tip the tiller backward. Block the tiller in position so that the tines are exposed.
4. Remove all vegetation, string, wire, and other material that may have accumulated on the axle between the inside set of tines.



WARNING

**TURN OFF ENGINE AND DETACH SPARK PLUG WIRE.  
ENGINE MUST BE COOL.**

## Engine Maintenance

Refer to the engine manual included in your parts packet for information on engine maintenance. Your engine manual provides detailed information and a schedule for performing the following:

1. Check oil level before each use and after 8 hours of operation.
2. Change oil after first 5-8 hours of operation. Change oil while engine is warm. Refill with new oil of recommended grade.
4. Check spark plug yearly or every 100 hours of operation.
5. Service air cleaner.
6. Keep engine and parts clean.
7. Check engine and equipment often for loose nuts and bolts.



WARNING

### **DO NOT STORE THE TILLER IN UNVENTILATED AREA**

*where fuel fumes may reach flame, sparks, pilot lights or other ignition source.*

**Drain fuel outdoors away from any ignition sources.**

Use only approved fuel containers.

**Never store equipment with gasoline in the tank** inside of a closed building where fumes may reach an open flame or spark. Allow the engine to cool before storing in any building.

Add a fuel stabilizer to gas tank and run for 10-15 minutes to prevent fuel from gumming up during an extended storage period.

### **Prepare for Storage**

Follow the steps below to prepare your tiller for storage. Read your engine manual for detailed instructions on preparing the engine for storage.

1. Protect wheels and axles from rust: Remove lock pin and slide wheel off hub. Coat the axles lightly with axle grease. Slide wheel back on hub and insert lock pin.
2. Drain fuel system completely following engine manufacturer's instructions or add fuel stabilizer to prevent fuel from gumming up during extended storage period.
3. While engine is still warm, drain the oil from the engine. Refill with fresh oil of the recommended grade.
4. Clean external surfaces, engine and cooling fan.
5. Remove spark plug, pour one ounce of SAE 30 oil into spark plug hole.
6. Plug hole and pull starter cord slowly to distribute oil evenly in cylinder head area.
7. Reinstall spark plug.
8. Transport unit to a suitable storage location. If you have chosen to use a fuel stabilizer and have not drained the fuel system, follow all safety instructions storage precautions in this manual to prevent the possibility of fire from the ignition of gasoline fumes. Remember, gasoline fumes can travel to distant sources of ignition and ignite, causing risk of explosion and fire.
9. If there is any possibility of unauthorized use or tampering, remove the spark plug and store it in a safe place before storing the tiller unit. Be sure to plug the spark plug hole to prevent foreign material from entering.

# Troubleshooting

PROBLEM	SOLUTION
Engine will not start	<ul style="list-style-type: none"> <li>• Add gas to gas tank.</li> <li>• Connect spark plug wire to spark plug</li> <li>• Throttle must be positioned at choke for a cold start</li> </ul>
Engine runs rough, floods during operation	<ul style="list-style-type: none"> <li>• Clean or replace air cleaner</li> </ul>
Engine is hard to start	<ul style="list-style-type: none"> <li>• Drain old fuel and replace with fresh. Use gas stabilizer at end of season</li> <li>• Make sure spark plug wire is securely attached to spark plug</li> <li>• Drive safety control levers must be released to neutral position to start the engine</li> <li>• Throttle is not in proper start position</li> </ul>
Engine misses or lacks power	<ul style="list-style-type: none"> <li>• Raise the tines for shallow tilling by lowering the depth regulator lever</li> <li>• Remove and clean fuel tank</li> <li>• Clean or replace air cleaner</li> <li>• Improper carburetor adjustment, take to authorized engine service center</li> <li>• Replace spark plug and adjust gap</li> <li>• Drain and refill gas tank and carburetor</li> </ul>
Engine will not stop when throttle control is positioned at stop	<ul style="list-style-type: none"> <li>• See engine manual to check and adjust the throttle linkage</li> </ul>
Tiller moves forward during starting	<ul style="list-style-type: none"> <li>• Drive lever must be released to start the engine</li> </ul>
Tiller is difficult to control when tilling (machine jumps or lurches forward)	<ul style="list-style-type: none"> <li>• Push downward on the handlebars raising the tines</li> <li>• Keep the tines raised slightly for shallower tilling on hard soils, then do a second pass going deeper</li> <li>• Raise the tiller depth regulator</li> </ul>
Tines do not rotate with Driver Safety Control Lever depressed	<ul style="list-style-type: none"> <li>• Drive cable is damaged or incorrectly adjusted</li> <li>• Drive belt is damaged</li> </ul>
Tines continue to rotate after the Driver Safety Control Lever is released	<ul style="list-style-type: none"> <li>• Drive cable is damaged or incorrectly adjusted</li> </ul>
Excessive heat build up in tine area during tilling	<ul style="list-style-type: none"> <li>• Clean the tine axle shaft</li> <li>• Check transmission fluid and fill if low</li> </ul>

# Warranty & Specifications

## IMPORTANT NOTICE

We, the manufacturer, reserve the right to change the product and/or specifications in this manual without notification. The manual is for information usage only and the pictures and drawings depicted herein are for reference only.

## Warranty Repair and Service

Do not return this product to the store for warranty issues or repair. Call our customer service department at **720-287-5182**, **1-877-487-8275**, or visit [www.dirtyhandtools.com](http://www.dirtyhandtools.com) for the location of the nearest service center.

Record the information below for future reference.

Model No. \_\_\_\_\_

Serial No. \_\_\_\_\_

Date of Purchase \_\_\_\_\_

Place of Purchase \_\_\_\_\_

## Specifications

SKU/Part No.	101571
Description	Front Tine Tiller
Engine	6.75 ft/lbs Gross Torque 149cc Kohler Engine* EPA/CARB Approved
Engine Oil Capacity**	0.63 quarts (0.6 liters)
Operating Speed	3600 RPM
Nominal Power Rating	4.476 kW
Tilling Width	15"
Tilling Depth	10"
Tires	6" diameter
Transmission	Neutral (disengaged), and Forward (engaged)
Transmission Capacity	18-22 ounces liquid grease (factory filled)
Dimensions	48"L x 21.25"W x 42.25"H (including handlebar)
Shipping Weight	70 Lbs.
Warranty	2 Year / 2 Year Limited Warranty

\*As rated by engine manufacturer

\*\* Not included, shipped without engine oil

Dirty Hand Tools® is a brand of  
 **FrictionlessWorld**  
1100 W 120th Ave., Suite 600  
Westminster, CO 80234 • 720-287-5182

For Service or Questions  
**Call 1-877-487-8275**  
**720-287-5182**  
[www.dirtyhandtools.com](http://www.dirtyhandtools.com)